

MultiScent²⁰ Screen

NOAR



A powerful and fully integrated device for experiencing fragrances in a unique, innovative and intuitive way.

Integrated solution for the exclusive Noar's technology with a 7 inch built-in touch screen.

Perfect for use at the Point of Sale.

Offers up to 20 fragrances for experimentation, with 100 trials each.

Noar's exclusive Dry Smell Technology

No residues or droplets are released in the air or on the consumer.

Try several products without mixing fragrances or confusing the senses.



Contact us:

noarbrasil.com.br
contato@noarbrasil.com.br

ORLANDI

Exclusive international
distributor in beauty sector
orlandi-usa.com

TECHNICAL DATA SHEET

MULTISCENT 20

BY NOAR

NOAR[®]

Noar Brasil Ind. Com. Frag. Digitais S.A.
Av. Alvaro Guimarães, 2.502 – Sala 2, Bloco B
São Bernardo do Campo – SP, Brasil
CEP 09810-010

contato@noarbrasil.com.br
noarbrasil.com.br

NAME: MultiScent
MODEL: MultiScent 20 Screen
CODE: TBD

Issued: September 13, 2022

DESCRIPTION:

MULTISCENT is an electronic device designed for olfactory experimentation that provides digital scent through dry air technology.

The device operates with a cartridge system, which can be replaced when empty.

The MULTISCENT 20 model allows the experimentation of 20 different fragrances.

The Multiscent 20 Screen has its own touchscreen and the same capabilities as a consumer tablet. It is operated using an application installed in its own memory.

DRAWINGS:

Dimensions in mm

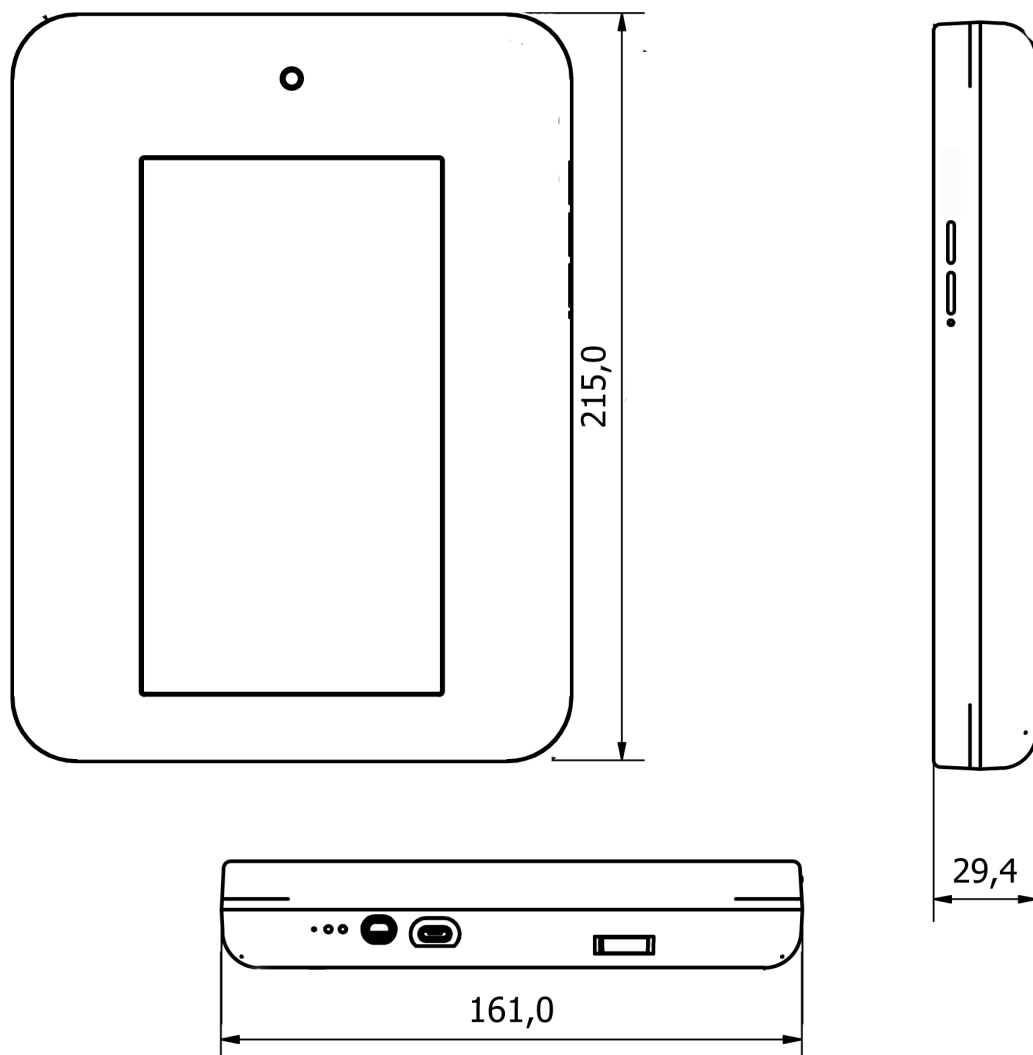

TECHNICAL DATA SHEET MULTISCENT 20 BY NOAR

NOAR®

Noar Brasil Ind. Com. Frag. Digitais S.A.
Av. Alvaro Guimarães, 2.502 – Sala 2, Bloco B
São Bernardo do Campo – SP, Brasil
CEP 09810-010

contato@noarbrasil.com.br
noarbrasil.com.br

Issued: September 13, 2022

NAME: MultiScent
MODEL: MultiScent 20 Screen
CODE: TBD

- 1 - Fragrance Output
- 2 - Camera
- 3 - Touch Screen
- 4 - Volume +
- 5 - Volume -
- 6 - Tablet reset hole
- 7 and 8 - Ventilation windows
- 9 - Cartridge change lid
- 10 - Exhaust fan
- 11 - Mini USB cable input
- 12 - On / Off Button
- 13 - QR code and device ID

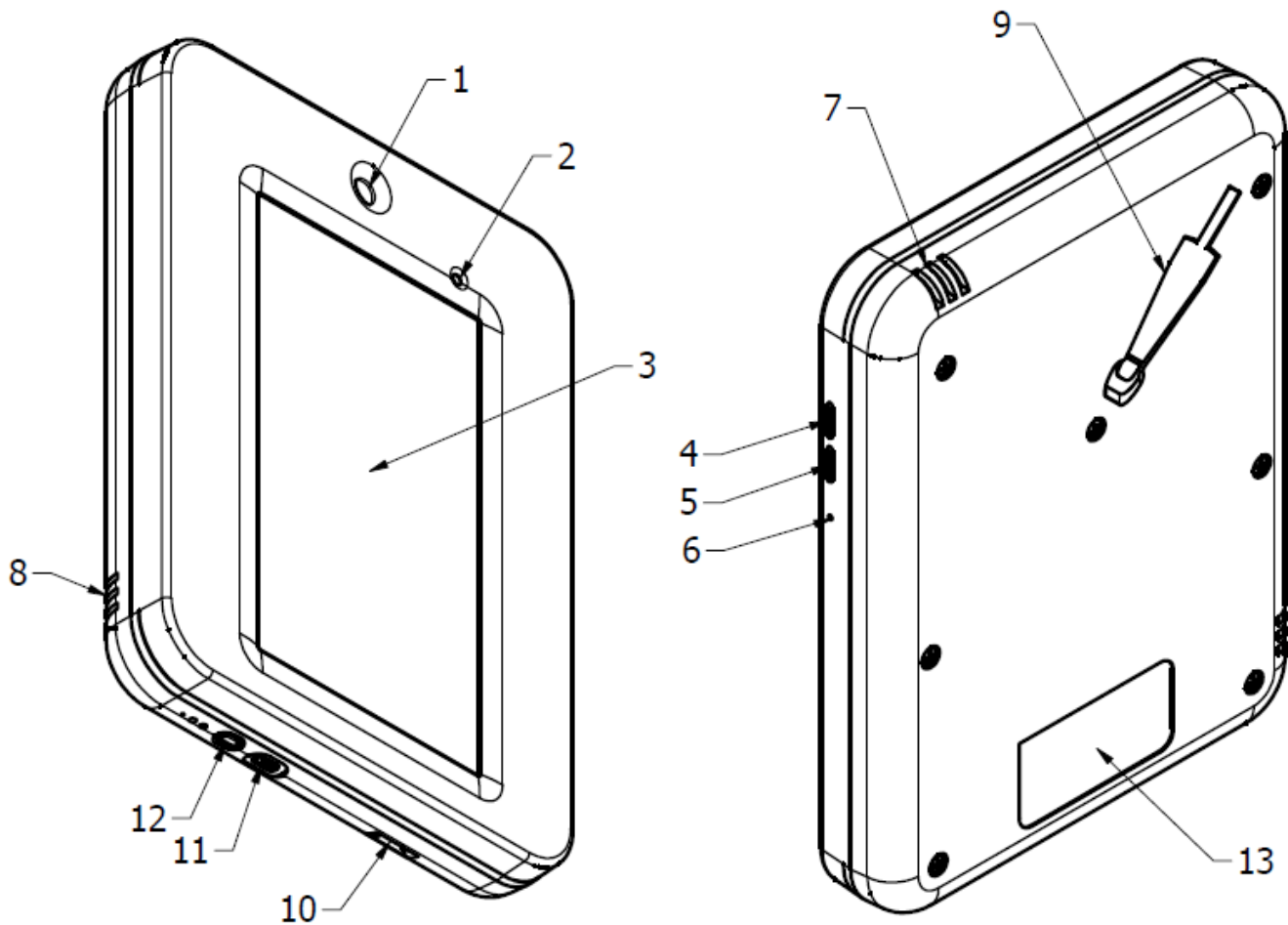

**TECHNICAL DATA SHEET
MULTISCENT 20
BY NOAR**

NOAR[®]

Noar Brasil Ind. Com. Frag. Digitais S.A.
Av. Alvaro Guimarães, 2.502 – Sala 2, Bloco B
São Bernardo do Campo – SP, Brasil
CEP 09810-010

contato@noarbrasil.com.br
noarbrasil.com.br

Issued: September 13, 2022

NAME: MultiScent
MODEL: MultiScent 20 Screen
CODE: TBD

SPECIFICATIONS:

DIMENSIONS: 215mm X161mm X 29,4mm
8 1/2" X 6 3/8" X 1 3/16"

WEIGHT: 690g / 1,52 pounds

SCREEN: 7 Inch 1024*600 IPS LCD
Multi Touch 5 Point Capacitive Touch Screen (Glass)

OPERATIONAL SYSTEM: Android 10

STORAGE: 32 GB Storage and 128GB Expandable
2 GB RAM

PROCESSOR: SC9863 OctaCore (Processor) @ 2.8GHz

CAMERA: 2MP Front camera with LED Flash

Powerful Graphics Processor (GPU) Mali-400 MP2
Inbuilt GPS Chip and Antenna
Inbuilt FM Radio
BT Connectivity
Wi-Fi Connectivity
Type C Port
WiFi HotSpot Tethering
OTG Support
Supports 480p, 720p and 1080p HD Videos